

Smartgen®

HGM6000K Series

Automatic Generator Module

OPERATING MANUAL

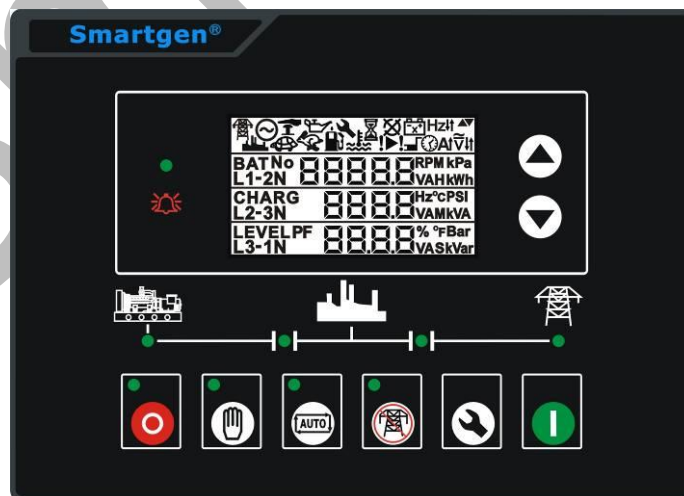
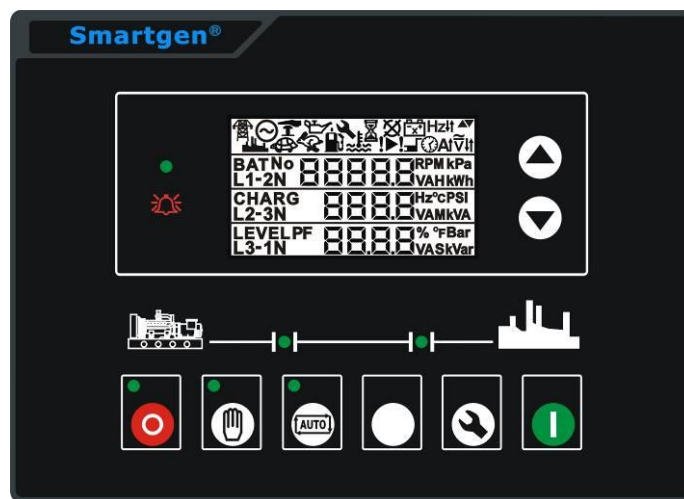

Smartgen Electronic

Smartgen®

Smartgen Electronic Equipment Co., Ltd
No.28 JinSuo Road
Zhengzhou
Henan Province
P.R.China

Tel: 0086-371-67988888/67981888

0086-371-67991553/67992951/67992952

0086-371-67981000(overseas)

Fax: (0086)-371-67992952/67981000

Web: <http://www.smartgen.com.cn>

<http://www.smartgen.cn>

Email: sales@smartgen.com.cn

All rights reserved. No part of this publication may be reproduced in any material form (including photocopying or storing in any medium by electronic means or other) without the written permission of the copyright holder.

Applications for the copyright holder's written permission to reproduce any part of this publication should be addressed to Smartgen Electronics at the address above.

Any reference to trademarked product names used within this publication is owned by their respective companies.

Smartgen Electronics reserves the right to change the contents of this document without prior notice.

Software Version

Version	Date	Note
1.0	2009-07-18	Original release.
1.1	2009-09-01	Add oil pressure sensor SGX, temperature sensor SGX, and power on mode select.
1.2	2009-11-01	Add edition display function.
1.3	2009-12-25	Amend sensor curve function.
1.4	2010-06-17	Add output port high speed output function; Add input port 4 and 5 function. Amend products appearance picture, panel cutout size long wide all increase 2, controller applicable working temperature.
1.5	2010-07-07	Optimize some detail parts of the operator Manual.
1.6	2010-12-03	Gens speed and frequency was changed to a screen.
1.7	2011-06-20	Modify single-phase/three phase input of parameter range.

CONTENT

1	SUMMARY	4
2	PERFORMANCE AND CHARACTERISTICS.....	4
3	SPECIFICATION.....	6
4	OPERATION	6
4.1	KEY FUNCTION	6
4.2	DISPLAY DESCRIBE	7
4.3	AUTOMATIC OPERATION.....	9
4.4	MANUAL OPERATION.....	10
5	PROTECTION.....	11
5.1	WARN.....	11
5.2	SHUTDOWN ALARM.....	13
6	CONNECTING TERMINAL	14
7	PARAMETER RANGE AND DEFINE.....	17
7.1	PARAMETERS TABLE (TABLE 1).....	17
7.2	OUTPUT 1-4 TABLE (TABLE 2).....	25
7.3	DIGIT INPUT 1-5 TABLE (TABLE 3).....	26
7.4	SENSOR (TABLE 4)	26
7.5	CONDITION OF CRANK SUCCEED (TABLE 5).....	27
8	SETTING PARAMETER	28
9	SENSOR SETTINGS.....	29
10	COMMISSIONING	30
11	TYPICAL WIRING DIAGRAM.....	31
12	INSTALLATION	32
13	FAULT FINDING	33

1 SUMMARY

HGM6000K series Genset controller integrating digital, intelligent and network techniques is used for automatic control system of diesel generator. It can carry out functions including automatic start/stop, data measure and alarm protective. The controller uses LCD display, with operation easy and reliable.

HGM6000K series Genset controller uses micro-processing technique which can carry out precision measure, constant value adjustment, timing and threshold setting and etc. functions. It can be widely used in all types of generator automatic control system for compact structure, advanced circuits, simple connections and high reliability, can be widely applied to various types of generating units automation system.

2 PERFORMANCE AND CHARACTERISTICS

- HGM6000K controller has four types:

HGM6010K/6010KC: Automatic Start Module, it controls genset to start/stop by remote start signal;

HGM6020K/6020KC: Based on HGM6010K/6010KC and add mains AC monitoring, Mains/Genset automatic switching control functions (AMF), especially suitable for the automation system composed by Mains and Genset.

Note1: HGM6010KC/6020KC with RS485 interface, HGM6010K/6020K without RS485 interface.

Note2: And then take HGM6010KC/6020KC with text as an example to describe.

- Using microprocessor as a core, graphics LCD with big screen and backlight, display between character and icon display, key touch for operation;
- Have a RS485 port with Modbus communication protocol;
- Adapt to 3phase-4wires, single phase-2wires or 2phase-3 wires (120/240V) , 50/60Hz AC power system;
- Measure and display 3 phase voltage, 3 phase current, frequency, power etc. parameter of Mains and Gens;
- Precision measure and display of

Mains

Line voltage (Uab, Ubc, and Uca)

Phase voltage (Ua, Ub, and Uc)

Frequency HZ

Load

Power Current IA, IB, IC

Active power KW

Gens

Line voltage (Uab, Ubc, and Uca)

Phase voltage (Ua, Ub, and Uc)

Frequency HZ

Inactive power KVar

Apparent power KVA

Power factor Cos

Accumulate total gens power kWh

- Mains have over voltage, under voltage, loss phase function; Gens have over voltage, under voltage, over frequency, under frequency, over current function;
- Precision measure and display parameters about Engine,
 - Temp. (WT), °C/ °F both are display
 - Oil pressure (OP), kPa/Psi/Bar all be display
 - Fuel oil level (FL), % (unit)
 - Speed (SPD), RPM (unit)
 - Voltage of Battery (VB) V (unit)
 - Voltage of Charger (VD) V (unit)
 - Hour count (HC) can accumulate Max. 999999 hours.
 - Starting up can accumulate Max.999999 times.
- Control protection: Automatic crank/stop of diesel engine, load transfer(ATS control) and completely faults display protection;
- With ETS, idle control, pre-heat control, raises speed control functions, and all types of them are belong to relay output;
- Parameters setting: Allow user to modify setting and store them by inside internal FLASH memory, the parameters cannot be lost even with power off. All of parameters can be set not only from the front panel, but by PC via SG72 (an adaptor, USB-LINK-RS485) module; or, through RS485 port via PC;
- Most of temperature, pressure, oil level sensor can be directly used, and also user can define sensor curve by themselves;
- Multiple crank disconnection conditions can be selected.(Speed sensor, oil pressure, gens);
- Power supply range is wide(8~35)VDC, accommodating to different starting battery voltage environments;
- All parameters use digital modulation, abandoning analog modulation using conventional electronic potentiometer, more reliability and stability;
- Modular configuration design, Flame Retardant ABS plastic shell, inserted type connection terminals, flush type installation, compact structure, easy installation.







3 SPECIFICATION

Operating Voltage	DC8.0V to 35.0V, Continuous
Power Consumption	<3W(Standby mode: ≤2W)
Alternator Input Range 3-Phase 4 Wire 2-Phase 3 Wire Single phase 2 Wire	15VAC - 360VAC (ph-N) 15VAC - 360VAC (ph-N) 15VAC - 360VAC (ph-N)
Frequency	50Hz - 60Hz
Magnetic AC voltage	1.0V to 24V (effective value)
Magnetic AC Frequency	10,000 Hz (max)
Start Relay Output	16 Amp DC28V at supply voltage.
Fuel Relay Output	16 Amp DC28V at supply voltage.
Auxiliary Relay Output (1-4)	(1) 7Amp DC28V at supply voltage, (2)7Amp 250VAC free voltage contact, (3, 4)16Amp 250VAC free voltage contact.
Overall Dimensions	209mm x 153mm x 55mm
Panel cutoff	186mm x 141mm
Operating Temp. Range	Temperature: (-25~+70)°C Humidity: (20~90)%
Storage Condition	Temperature: (-30~80)°C
Protective Level	IP55: when waterproof rubber ring added between controller and its panel. IP42: when waterproof rubber ring not have between controller and its panel.
Insulation Intensity	Object: among in input/output/power Quote standard: IEC688-1992 Test way: AC1.5 kV / 1min 3mA leakage current
C. T. Secondary	5A (rated)
Weight	0.69kg

4 OPERATION

4.1 KEY FUNCTION

	Stop/ Reset	Can stop genset under mode of Manual/Auto; Can reset alarming under Stop; To test panel indicators are OK or not, pressing this
---	-------------	---

		key at least 3 seconds; During stopping process, press this again can stop genset immediately.
	Start	To start genset under Manual or Auto mode.
	Manual	Pressing this key will set the module into manual mode.
	Automatic	Pressing this key will set the module into automatic mode.
	Running with load	Pressing and controller is under manual testing mode. Under this mode, genset will run with load automatic when gens are normal. (HGM6010KC without)
	Set/ Confirm	Enters into Set menu after pressing this, and can shift cursor to confirm.
	Page up /increase	Screen pages turning; Shift cursor and increase its position no. in setting.
	Page down /decrease	Screen pages turning; Shift cursor and decrease its position no. in setting.

4.2 DISPLAY DESCRIBE

Mains: line voltage Uab, Ubc, Uca

Mains: phase voltage Ua, Ub, Uc



L1-2 380 _V
L2-3 380 _V
L3-1 380 _V

L1- N 220 _V
L2- N 220 _V
L3- N 220 _V

Mains: frequency (Hz) F1

Genset: line voltage Uab, Ubc, Uca



500 ^{Hz}

L1-2 380 _V
L2-3 380 _V
L3-1 380 _V

Genset: phase voltage Ua, Ub, Uc

Genset: speed, frequency (Hz) F2

L1- N 220 _V
L2- N 220 _V
L3- N 220 _V

500 ^{Hz}
1500 ^{RPM}

Load: current IA, IB, IC

⊗	
L1	500 A
L2	500 A
L3	500 A

Load: active power (kW), inactive power (kVar), apparent power (kVA)

⊗	
	320 kW
	240 kVA
	400 KVar

Accumulate total gens power kWh
Power factor

⊗	
	701 kWh
PF	0.80

Battery voltage BAT, Charger voltage CHARG, Liquid level**%

⊗	
BAT	27.6V
CHARG	28.3V
LEVEL	67%

Water temperature

⊗	
	90 °C
	194 °F

Gens oil pressure

⊗	
	5.60 Bar
	5.60 kPa
	8.12 PSI

Gens hours count

⊗		⊙
	435 H	
	42 M	
	50 s	

Gens starts count

⊗	
N	136

Gens status, Gens status delay countdown display

⊗	
No	4
	3 s

4.3 AUTOMATIC OPERATION

This mode is activated by pressing the . LED indicator is illuminating beside the button confirms this action.

Sequence of Auto Start,

1. HGM6020KC, When Mains is abnormal (over and under voltage, or miss phase), enters into mains “abnormal delay” and LCD display count down time. When mains abnormal delay is over, enter into “start delay”.
2. HGM6010KC, entries into “start delay” as soon as “Remote Start” is input valid.
3. “Count down” of start delay is displayed in LCD.
4. When start delay is over, preheat relay is outputting (if be equipped), “preheat start delay XX s” is displayed in LCD.
5. When preheat relay is over, oil relay is outputting 1s and then start relay-output; if genset fails in starting during “cranking time”, the oil and start relays stop outputting and enters into “crank rest time” and wait for next attempt.
6. If genset fails in starting within setting attempt times, LCD start-up failure alarming icon  flash.
7. Whatever times to start genset successfully, it will enter into “safety on time”. During this period, alarms of low oil pressure, hi-temperature, under speed, charge fail and Aux. input (been configured) are inactive. As soon as this delay is over, genset will enter into “start idle delay” (if this be configured).
8. During “start idle delay”, alarms of under speed, under frequency, under voltage are inactive. As soon as this delay is over, genset will enter into “warming up time delay” (if this be configured).
9. When “warming up time delay” is over, gens status indicator is light if gens normal. If alternator’s voltage, frequency meets to requirement of load, gens will close and relay is outputting, then genset will enter into normal running with load and gens indicator is light; if genset voltage and frequency is abnormal, controller will alarm and stop engine (gens alarming is displayed LCD).

Sequence of Auto Stop,

1. HGM6020KC, when Mains recovery during genset running, enters into mains voltage “normal delay” and its indicator light after Mains normal be confirmed. “Start delay” is beginning.
2. HGM6010KC, genset enters into “stop delay” as soon as “Remote Start” putting is inactive.

3. As soon as “stop delay” is over, genset enters into “High Speed cooling delay”. Mains are close and breaker is disconnected. After switch “rest time delay”, mains are close and relay is output as well as with loading. Gens’ indicator is dark while mains’ light.
4. Idle relay has power and outputs as soon as entering “stop idle relay” (If this been configured).
5. When enters “ETS relay”, ETS relay has power and outputs. Oil relay’s output is disconnected.
6. When genset enters “stop time”, automatic to decide whether genset is stopped or not.
7. When genset will enter into “over stop time” as soon as genset is stopped. If genset failed to stop and controller will alarm (“stop failed” will be displayed in LCD).

Note: this page is nonce genset status, genset status delay countdown display, for example:



	R	
No		4
		3 s



At the first line, NO 4 is the Start interval state; 3s is the countdown to remain time intervals of Start interval.



Gens Status List:

0: Genset Waiting 1: Start preheat 2: Fuel output 3: Start 4: Start Interval
 5: Safety run 6: Start Idling 7: Start warm-up 8: Wait for the Load 9: Normal Run
 10: Stop for cooling 11: Stop idling 12: ETS stop 13: Wait for stop steady 14: Shutdown failures

4.4 MANUAL OPERATION

1. HGM6020KC, Auto starts mode is active when press  and its indicator is illuminating. Press , then controller under “Manual Test Mode” and its indicator is illuminating. Under the both modes, press  to start genset, and it can automatic detect start successfully and accelerate to Hi-speed running. If there is Hi-temperature, low oil level and voltage abnormal during diesel genset

running, controller can protect genset to stop quickly (detail procedures please refer to No.4~9 of Auto start operation). Under “Manual Test Mode ”, genset with load is decided by Mains is normal or not. If mains are normal, loading switch is never transferred; while mains are abnormal, loading switch is transferred into gens side. Under “Manual Test Mode ”, after genset runs well in high speed, no matter mains is normal or not, loading switch must be transferred into gens side.

2. HGM6010KC, Auto starts mode is active when press , and its indicator is illuminating. Then press  to start genset, it can automatic detect start successfully and genset automatic accelerates to Hi-speed running. If there is Hi-temperature, low oil level and voltage abnormal during diesel genset running, controller can protect genset to stop quickly (detail procedures please refer to No.4~9 of Auto start operation). After genset runs well in High speed, controller will send signal of gens close.
3. Manual stop, press  can shutdown the running genset (detail procedures please refer to No.3~7 of Auto stop operation).

5 PROTECTION

5.1 WARN

Warns are non-critical alarm conditions and do not affect the operation of the genset system; they serve to draw the operators attention to an undesirable condition.

In the event of a warning, the module will display at the last screen of LCD.

Warn is shown as the below:

HIGH ENGINE TEMPERATURE WARN, if the module detects that the engine coolant temperature has exceeded the high engine temperature setting level after the Safety On timer has expired and the input of **Inhibit WTH stop** is activated, a warn will occur. At the same time LCD screen  icon lighten.

LOW OIL PRESSURE WARN, if the module detects that the engine oil pressure

has fallen below the low oil pressure setting level after the Safety On timer has expired and the input of **Inhibit OPL stop** is activated, a warning will occur. At the same time LCD screen  icon lightens.

LOSS OF SPEED SIGNAL WARN, if the speed sensing signal is lost, a warning will occur and the lost speed delay set to zero, a warning will occur. At the same time LCD screen  icon lightens.

GENSET OVER CURRENT WARN, if the module detects a genset output current in excess of the setting and the over current delay set to zero, a warning is initiated. At the same time LCD screen  icon lightens.

FAIL TO STOP WARN, if the module detects the engine is still running when the 'Fail to stop timer' expires, a warning is initiated. At the same time LCD screen  icon lightens.

START BATTERY OVER VOLTAGE WARN, if the module detects that the plant DC supply has risen above the high volts setting level, a warning is initiated. At the same time LCD screen  icon lightens.

START BATTERY UNDER VOLTAGE WARN, if the module detects that the plant DC supply has fallen below the low volts setting level, a warning is initiated. At the same time LCD screen  icon lightens.

LOW FUEL LEVEL WARN, if the module detects that the engine oil level has fallen below the low level setting level has expired, a warning will occur. At the same time LCD screen  icon lightens.

FAILED TO CHARGE WARN, if the module detects that the charge of volts has fallen below the setting level has expired, a warning will occur. At the same time LCD screen  icon lightens.

GENSET OVER VOLTAGE WARN, if the module detects a genset output voltage in excess of the setting a warning is initiated. At the same time LCD screen  icon lightens.

GENSET UNDER VOLTAGE WARN, if the module detects a genset output voltage below the setting a warning is initiated. At the same time LCD screen  icon lightens.

OVER SPEED WARN, if the engine speed exceeds the setting value a warning is initiated. At the same time LCD screen  icon lightens.

UNDER SPEED WARN, if the engine speed falls below the setting value after the Safety On timer has expired, a warning is initiated. At the same time LCD screen

 icon lighten.

GENSET OVER FREQUENCY WARN, if the module detects a genset output frequency in excess of the setting value a warn in is initiated. At the same time LCD screen **Hz↑** icon lighten.

GENSET UNDER FREQUENCY WARN, if the module detects a genset output frequency below the setting value after the Safety On timer has expired, a warning is initiated. At the same time LCD screen **Hz↓** icon lighten.

5.2 SHUTDOWN ALARM

Shutdowns are latching and stop the genset. The alarm must be cleared, and the fault removed to reset the module.

NOTE: The alarm condition must be rectified before a reset will take place. If the alarm condition remains it will not be possible to reset the unit (The exception to this is the Low Oil Pressure alarm, as the oil pressure will be low with the engine at rest).

EMERGENCY STOP, removal of the **+ve DC** Supply from the Emergency Stop input initiates the following sequence, firstly it will initiate a controlled shutdown of the genset and prevent any attempt to restart the genset until the Emergency stop push-button has been reset. Secondly it removes the **+ve DC** supply from both the Fuel Solenoid and Starter Solenoid. At the same time LCD screen  flicker.

HIGH ENGINE TEMPERATURE, if the module detects that the engine coolant temperature has exceeded the high engine temperature setting level after the **Safety On** timer has expired, a shutdown will occur. At the same time LCD screen  flicker.

LOW OIL PRESSURE, if the module detects that the engine oil pressure has fallen below the low oil pressure setting level after the **Safety On** timer has expired, a shutdown will occur. At the same time LCD screen  flicker.

OVERSPEED, if the engine speed exceeds the setting value a shutdown is initiated. At the same time LCD screen  flicker.

UNDERSPEED, if the engine speed falls below the setting value after the **Safety On** timer has expired, a shutdown is initiated. At the same time LCD screen  flicker.

LOSS OF SPEED SIGNAL, if the speed sensing signal is lost, a shutdown is initiated. At the same time LCD screen  flicker.

GENSET OVER FREQUENCY, if the module detects a genset output frequency

in excess of the setting value a shutdown is initiated. At the same time LCD screen **Hz↑** flicker.

GENSET UNDER FREQUENCY, if the module detects a genset output frequency below the setting value after the Safety On timer has expired, a shutdown is initiated. At the same time LCD screen **Hz↓** flicker.

GENSET OVER VOLTAGE, if the module detects a genset output voltage in excess of the setting value a shutdown is initiated. At the same time LCD screen **Ṽ↑** flicker.

GENSET UNDER VOLTAGE, if the module detects a genset output voltage below the setting value after the Safety On timer has expired, a shutdown is initiated. At the same time LCD screen **Ṽ↓** flicker.

GENSET OVER CURRENT, if the module detects a genset output current in excess of the setting value is initiated, a shutdown is initiated. At the same time LCD screen **A↑** flicker.

FAIL TO START, if the engine does not fire after the pre-set number of attempts has been made a shutdown will be initiated. At the same time LCD screen **!⏏** flicker.

AUXILIARY INPUTS, if an auxiliary input has been configured as a shutdown the appropriate information will be displayed. At the same time LCD screen **!▶** flicker.

NO GENSET ALARM SHUTDOWN, when the controller detects to genset frequency equals to zero, the controller sends out the shutdown alarm signal. At the same time LCD screen **Hz↓** flicker.

TEMPERATURE SENSOR OPEN CIRCUIT, when the controller detects to temperature sensor open circuit, the controller sends out the shutdown alarm signal. At the same time LCD screen **⚡** flicker.

OIL PRESSURE SENSOR OPEN CIRCUIT, when the controller detects to oil pressure sensor open circuit, the controller sends out the shutdown alarm signal. At the same time LCD screen **🛢️** flicker.

6 CONNECTING TERMINAL

HGM6010KC compared with HGM6020KC, is less a Mains three phase AC input terminal. The HGM6010KC and HGM6020KC backplane is as following.

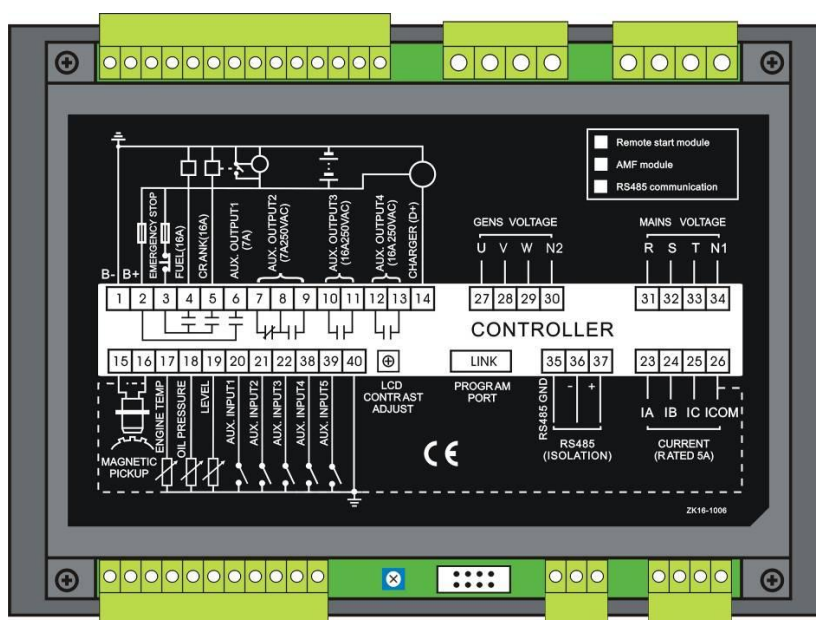

Pin	Function	Dim	Description	
1	DC plant supply input (-ve)	2.5mm	System DC negative input. (Battery Negative).	
2	DC plant supply input (+ve)	2.5mm	System DC positive input. (Battery Positive). (Recommended Maximum Fuse 20A)	
3	Emergency stop input	2.5mm	Plant supply +ve. Also supplies fuel & start outputs.	
4	Fuel relay output	1.5mm	Plant supply +ve from pin 3. 16 Amp rated.	
5	Start relay output	1.5mm	Plant supply +ve from pin 3. 16 Amp rated.	Connect to starter starting coil.
6	Auxiliary output relay 1	1.5mm	Plant supply +ve from pin 2. 7 Amp rated.	Reference table 2
7	Auxiliary output relay 2	1.5mm	Closed output, 7 Amp rated.	
8			Relay common point	
9			Open output, 7 Amp rated.	
10	Auxiliary output relay 3	2.5mm	Free volt contacts.	
11	Auxiliary output relay 4	2.5mm	16 Amp rated	
12				
13				
14	Charge fail / excite	1.0mm	Do not connect to ground (battery -ve)	

Pin	Function	Dim	Description
15	Magnetic pickup +ve		Connect to Magnetic Pickup device
16	Magnetic pickup -ve		
17	Temp. sensor input	Connecting water/cylinder temperature resistance type sensor.	Reference table 4
18	Oil pressure input	Connect to oil pressure sensor.	
19	Liquid level input	Connect to liquid level sensor.	
20	Auxiliary input 1	1.0mm	Switch to -ve
21	Auxiliary input 2	1.0mm	Switch to -ve
22	Remote start input	1.0mm	Switch to -ve
23	CT secondary for A	1.5mm	Connect to secondary of A monitoring CT
24	CT secondary for B	1.5mm	Connect to secondary of B monitoring CT
25	CT secondary for C	1.5mm	Connect to secondary of C monitoring CT.
26	CT secondary common	1.5mm	See also back install instructions.
27	Gens A voltage monitoring	1.0mm	Connect to Genset A output (Recommend 2A fuse)
28	Gens B voltage monitoring	1.0mm	Connect to Genset B output (Recommend 2A fuse)
29	Gens C voltage monitoring	1.0mm	Connect to Genset C output (Recommend 2A fuse)
30	Gens neutral input	1.0mm	Connect to Genset neutral terminal.
31	Mains A voltage monitoring	1.0mm	Connect to mains A output. (Recommend 2A fuse)
32	Mains B voltage monitoring	1.0mm	Connect to mains B output. (Recommend 2A fuse)
33	Mains C voltage monitoring	1.0mm	Connect to mains C output. (Recommend 2A fuse)
34	Mains neutral input	1.0mm	Connect to mains neutral terminal.
35	RS485 port common GND	0.5mm	Use only 120Ω RS485 approved cable.
36	RS485 port A(-)	0.5mm	
37	RS485 port B(+)	0.5mm	
38	Auxiliary input 4	1.0mm	Switch to -ve
39	Auxiliary input 5	1.0mm	Switch to -ve

Pin	Function	Dim	Description
40	Common port	1.0mm	Auxiliary input common port

Note:

1. These terminals of 31, 32, 33, and 34 are not used for HGM6010KC module.
2. Back LINK interface as a parameter programming interface, used by SG72 adapter PC controller programming.

7 PARAMETER RANGE AND DEFINE

All parameters of HGM6000K series as follows:

Note: small brackets set item number 6010KC.

7.1 PARAMETERS TABLE (TABLE 1)

Num	Parameter	Range	Default	Remark
P 01	Mains volt normal delay	(0-3600)s	10	Mains transient delay, suited for ATS(automatic transfer switch)
P 02	Mains volt abnormal delay	(0-3600)s	5	
P 03	Mains under volt	(30-360)V	184	When mains voltage is under than the point, mains under voltage are active. When the point is zero, mains under voltage are disabled.
P 04	Mains over volt	(30-360)V	276	When mains voltage is over than the point, mains over voltage are active. When the point is 360V, mains over voltage are disabled.
P 05	Transfer switch interval	(0-99.9)s	1.0	It's the delay from mains is opened to genset closing or from genset is opened to mains closing.
P 06 (P01)	Start delay	(0-3600)s	1	It's the delay from remote start signal is active or mains is failure, to start genset.
P 07 (P02)	Stop delay	(0-3600)s	1	It's the delay from remote start signal is inactive or mains is normal, to stop genset.

HGM6000K Series Automatic Generator Module

Num	Parameter	Range	Default	Remark
P 08 (P03)	Number of Crank	(1-10)Times	3	When engine start no success, most of cranking numbers. When reach setting crank numbers, controller send out start fail signal.
P 09 (P04)	Preheat time	(0-300)s	0	Before the starter adds the electricity, preheat plug add to the electricity in advance.
P 10 (P05)	Cranking time	(3-60)s	8	The starter adds the time of the electricity each time.
P 11 (P06)	Crank interval time	(3-60)s	10	When the engine start not successful, in the second plus electric before the start of the waiting time.
P 12 (P07)	Safe run time	(1-60)s	10	At this time, low oil pressure, high water temperature, under speed, under frequency, under voltage and charging failure and auxiliary input (configured) alarm is void volume.
P 13 (P08)	Start idle time	(0-3600)s	0	Start genset idle running time.
P 14 (P09)	Warming up time	(3-3600)s	10	Genset entered high speed operation, in the warm-up before closed for time.
P 15 (P10)	Cooling time	(3-3600)s	10	After unloading in genset, the time needed to cool before shutdown.
P 16 (P11)	Stop idle time	(0-3600)s	0	When stop idling genset running time.
P 17 (P12)	ETS solenoid hold	(0-120)s	20	It's the delay for energizing to stop.

HGM6000K Series Automatic Generator Module

Num	Parameter	Range	Default	Remark
P 18 (P13)	Fail to stop delay	(0-120)s	0	When "ETS solenoid shutdown output time" for zero, idle time delay stop steady to time, and when "ETS solenoid hold output time" is not equal to zero, from ETS solenoid shutdown delay end to stop steady need of time.
P 19 (P14)	ATS close time	(0-10)s	5.0	Mains or Genset switch closing pulse width, when it is zero, output is continuous.
P 20 (P15)	Flywheel teeth	(10-300)	118	The flywheel teeth on engine starter teeth, used for starters separation condition judgment and engine speed detection, see behind the installation instructions.
P 21 (P16)	Gens abnormal delay	(0-20.0)s	10.0	Too high or too low voltage genset alarm delay.
P 22 (P17)	Gens over volt shutdown	(30-360)V	264	When genset voltage is over than the point, genset over shutdown voltage is active. When the point is 360V, genset over voltage is disabled.
P 23 (P18)	Gens under volt shutdown	(30-360)V	196	When genset voltage is under than the point, genset under shutdown voltage is active. When the point is 30V, genset under voltage is disabled.
P 24 (P19)	Under speed shutdown	(0-6000)RPM	1200	When the engine speed is under than the point and hold great than 10 seconds, genset under shutdown speed is active.

HGM6000K Series Automatic Generator Module

Num	Parameter	Range	Default	Remark
P 25 (P20)	Over speed shutdown	(0-6000)RPM	1710	When the engine speed is over than the point and hold great than 2 seconds, genset over shutdown speed is active.
P 26 (P21)	Gens under freq shutdown	(0-75.0)Hz	45.0	When genset frequency is low than the point, genset low frequency shutdown and hold great than 10 seconds is active.
P 27 (P22)	Gens over freq shutdown	(0-75.0)Hz	57.0	When genset frequency is over than the point and hold great than 2 seconds, genset over shutdown frequency is active.
P 28 (P23)	High temperature shutdown	(80-140)°C	98	When engine temperature sensor value is large than this point and remain for 2 seconds, send out shutdown alarm. When the value is 140, send out warning alarm. (It's suited for engine temperature sensor only).
P 29 (P24)	Low oil pressure shutdown	(0-400)kPa	103	When engine oil pressure sensor value is less than this point and remain for 2 seconds, send out shutdown alarm. When the value is zero, send out warning alarm. (It's suited for oil pressure sensor only).
P 30 (P25)	Low Fuel level	(0-100)%	10	When low Fuel level sensor value is less than this point and remain for 10 seconds, send out warning alarm.
P 31 (P26)	Lose speed delay	(0-20.0)s	5.0	When speed is zero and remain for the delay, send out shutdown alarm. When the delay is zero, send out warning alarm.

HGM6000K Series Automatic Generator Module

Num	Parameter	Range	Default	Remark
P 32 (P27)	Gens over volt warn	(30-360)V	256	When genset voltage is over than the point, genset over warning voltage is active. When the point is 360V, genset over voltage is disabled.
P 33 (P28)	Gens under volt warn	(30-360)V	205	When genset voltage is under than the point, genset under warning voltage is active. When the point is 30V, genset under voltage is disabled.
P 34 (P29)	Under speed warn	(0-6000)RPM	1350	When the engine speed is under than the point, genset under warning speed is active.
P 35 (P30)	Over speed warn	(0-6000)RPM	1650	When the engine speed is over than the point, genset over warning speed is active.
P 36 (P31)	Gens under freq warn	(0-75.0)Hz	47.0	When genset frequency is low than the point, genset under warning frequency is active.
P 37 (P32)	Gens over freq warn	(0-75.0)Hz	55.0	When genset frequency is over than the point, genset over warning frequency is active.
P 38 (P33)	Charge volt fail	(0-30)V	6.0	During genset is running, when charge alternator WL/D+ voltage is low than this point and remain for 5 seconds, genset will warning alarm.
P 39 (P34)	Battery over volt	(12-40)V	33.0	When genset battery voltage is over than the point and hold for 20 seconds, battery over voltage signal is active. It's a warning alarm.

Num	Parameter	Range	Default	Remark
P 40 (P35)	Battery under volt	(4-30)V	8.0	When genset battery voltage is less than the point and hold for 20 seconds, battery under voltage signal is active. It's a warning alarm.
P 41 (P36)	High temperature warn	(80-140)°C	95	When engine temperature sensor value is large than this point, send out warning alarm. When the value is 140, send out warning alarm. (It's suited for engine temperature sensor only).
P 42 (P37)	Low oil pressure warn	(0-400)kPa	124	When engine oil pressure sensor value is less than this point send out warning alarm. When the value is zero, send out warning alarm. (It's suited for oil pressure sensor only)
P 43 (P38)	CT rate	(5-6000)/5	500	Current transformer rate
P 44 (P39)	Full load current	(5-6000)A	500	Mains or genset set maximum rated current.
P 45 (P40)	Over current shutdown percentage	(50-130)%	120	When the load current is over than the point, the over current delay is initiated.
P 46 (P41)	Over current shutdown delay	(0-3600)s	1296	When load current is over than the point and hold great than the timer, send out over current signal. When the delay is zero, over current is disabled.
P 47 (P42)	Over current warn percentage	(50-130)%	110	When the load current is over than the point, over current warn icon illume.
P 48 (P43)	Switching value output1 set	(0-11)	2	ETS solenoid to stop
P 49 (P44)	Switching value output 2 set	(0-11)	3	Idle control

HGM6000K Series Automatic Generator Module

Num	Parameter	Range	Default	Remark
P 50 (P45)	Switching value output 3 set	(0-11)	5	Close Gens
P 51 (P46)	Switching value output 4 set	(0-11)	6	Close mains (6010KC has no function).
P 52 (P47)	Aux. input1 set	(0-10)	1	High Temperature alarm switch input
P 53 (P48)	Aux. input 1 delay	(0-20.0)s	2.0	
P 54 (P49)	Aux. input 2 set	(0-10)	2	Low oil pressure input
P 55 (P50)	Aux. input 2 delay	(0-20.0)s	2.0	
P 56 (P51)	Aux. input 3 set	(0-10)	3	Auxiliary warning input
P 57 (P52)	Aux. input 3 delay	(0-20.0)s	2.0	
P 58 (P53)	Aux. input 4 set	(0-10)	6	Oil engine closed state input
P 59 (P54)	Aux. input 4 delay	(0-20.0)s	2.0	
P 60 (P55)	Aux. input 5 set	(0-10)	10	Remote start input
P 61 (P56)	Aux. input 5 delay	(0-20.0)s	2.0	
P 62 (P57)	Module power on	(0-2)	0	0: Stop mode 1: Manual mode 2: Auto mode
P 63 (P58)	Module address	(1-254)	1	
P 64 (P59)	Passwords set	(0-9999)	1234	
P 65 (P60)	Crank success condition select	(0-5)	2	Setting item is given in Table 5.
P 66 (P61)	Speed disconnect	(0-3000)RPM	360	When engine speed is large than this point, starter will disconnect.

HGM6000K Series Automatic Generator Module

Num	Parameter	Range	Default	Remark
P 67 (P62)	Freq disconnect	(10-30)Hz	14	When genset frequency is large than this point, starter will disconnect.
P 68 (P63)	OP disconnect	(0-400)kPa	200	When engine oil pressure is large than this point, starter will disconnect.
P 69 (P64)	Select AC system	0 3P 4L 1 2P 3L 2 1P 2L	0	3P4L(3 phase 4 wire)
P70 (P65)	Select temp. sensor	(0-8)	08	SGX
P71 (P66)	Select press sensor	(0-8)	08	SGX
P72 (P67)	Select liquid level sensor	(0-5)	03	SGD
P73 (P68)	Temperature sensor custom curve setting			Need to set up eight first acts of the current data set the number of items, the second act to set the resistance value of the third act to set the resistance value of the temperature corresponding to the value of.
P74 (P69)	Oil pressure sensor custom curve setting			Need to set up eight first acts of the current data set the number of items, the second act to set the resistance value, the third act to set the resistance value of the pressure corresponding to the value of.
P75 (P70)	Liquid level sensor custom curve setting			Need to set up eight first acts of the current data set the number of items, the second act to set the resistance value, the third act to set the resistance value of the value of the corresponding level.

7.2 OUTPUT 1-4 TABLE (TABLE 2)

Num	Content	Description
0	Not used	Output is no use when select this
1	Common alarm	The designated programmable output relay will energize when any warning or shutdown fault circuit has been activated.
2	ETS solenoid hold	The designated programmable output relay will energize when a stop signal has been activated. The output will remain ETS solenoid for pre-set timer once the engine has come to a complete stop, then de-energizes.
3	Idle control	The designated programmable output relay will energize when the idle delay is not zero. The output contact would typically be connected to the "idle/run" input control of an electronic governor.
4	Preheat control	The designated programmable output relay will energize during the preheat delay timer period and also energize until the engine receive a crank success signal. The preheat output is typically used for an engine starting aid such as glow plugs.
5	Close Gens	Switch genset breaker on.
6	Close Mains	Switch mains breaker on.(HGM6010KC)
7	Open ATS	When closing time set to zero, time off to continue, this function when the feeder, namely for continues when closed on, does not have this function.
8	Raise speed control	In the process of warm-up when he entered the suction, suck time for high-speed warm-up delay time. Raise speed auxiliary input effective disconnect.
9	Drop speed control	Enter into stop idling process or to ETS solenoid stop (when alarm stop) sucked, and suck time to stop idling delay time. Drop speed when the auxiliary valid disconnect.
10	Pre-supply oil control	
11	High speed output	High speed warm-up, ready to on-load, normal operating, output after high speed cooling.

7.3 DIGIT INPUT 1-5 TABLE (TABLE 3)

Num	Content	Description
0	Not used	
1	High Temp. input	After the end of the delay in the safe operation, if the signal is active, genset will immediately alarm shutdown.
2	Low OP alarm input	
3	Auxiliary warn input	Auxiliary warn alarm digital input.
4	Auxiliary shutdown alarm input	When power on, if active, genset will shut down immediately.
5	Stop after cooled	During engine running, if the engine occur high temperature shutdown, when the input is active, the engine will first initiate cooling delay and then stop, else will stop immediately.
6	Gens closed input	The input state of genset closed.
7	Mains closed input	The input state of Mains closed.
8	Inhibit WTH STOP	When it is active, during engine running, if the engine appears high temperature, the engine will only send out high temperature warning alarm, not stop.
9	Inhibit OPL STOP	When it is active, during engine running, if the engine appears low oil pressure, the engine will only send out low oil pressure warning alarm, not stop.
10	Remote start input	In automatic state, controller remote starts the signal effectively when starting.

7.4 SENSOR (TABLE 4)

Num	Content	Remark
1	Temperature Sensor	0 Not used 1 Defined Res. Type 2 VDO 3 SGH(Huanghe sensor) 4SGD(DongKang sensor) 5 CURTIS 6 DATCON 7 VOLVO-EC 8 SGX Defined input resistance range is 0-999.9 ohm, factory default is SGX
2	Pressure Sensor	0 Not used 1 Defined Res. Type 2 VDO 10Bar 3 SGH(Huanghe sensor) 4 SGD(DongKang sensor) Defined input resistance range is 0-999.9 ohm, factory default is SGX

Num		Content	Remark
		5 CURTIS 6 DATCON 10Bar 7 VOLVO-EC 8 SGX	
3	Fuel level Sensor	0 Not used 1 Defined RT 2 SGH 3 SGD 4 Reserved 1 5 Reserved 2	Defined input resistance range is 0-999.9 ohm, factory default is SGD

7.5 CONDITION OF CRANK SUCCEED (TABLE 5)

Num	Content
0	Magnetic sensor
1	Genset
2	Magnetic sensor+Genset
3	Magnetic sensor + Oil pressure
4	Genset + Oil pressure
5	Genset+Magnetic sensor + Oil pressure

1. The crank disconnect condition has three kinds, the magnetic pickup sensor and the genset voltage can be used alone, the oil pressure must be used with the magnetic pickup sensor and the genset voltage, the purpose is to make the starter and the engine to disconnect as soon as possible.
2. Magnetic pickup sensor is installed in the engine block number of magnetic device testing flywheel.
3. When choosing magnetic pickup sensor, ensure engine flywheel teeth setting, otherwise may appear over speeding shutdown or loss speed shutdown.
4. If the genset is not magnetic pickup sensors, please don't choose corresponding, otherwise this will occur fail to start or loss of speed alarm and shutdown.
5. If the genset has no oil pressure sensor, please don't choose corresponding.
6. If the genset starting conditions has not be selected, the controller will not measure and display the relative parameters (This can be applied to the pump set), if not choose magnetic pickup sensor, the speed signal will come from the generating AC signal.

8 SETTING PARAMETER

After controller powered on, press  to enter into the parameters setting menu:

● Set parameters

When entering password, entering "1234" can set the item 1 to 47 in the table (parameters table [Table 1]), entering "0318" can set all items.

NOTE:

- a. When the controller type is HGM6010KC, you will not have a table with a 1-5; the programmable output 1-4 will have no power of some mains switch output.
- b. Please modify the parameters (such as crank disconnect, input and output configuration, various time, etc.) in standby mode, otherwise it might alarm shutdown or other abnormal behavior.
- c. The over-voltage threshold must be greater than the under-voltage threshold; otherwise both will occur at the same time over-voltage and under-voltage situation.
- d. The over-speed threshold must be greater than under-speed threshold, otherwise you will receive both the over speed and under speed.
- e. As far as possible set the frequency (crank disconnect) to lower numerical, in order to quickly crank disconnect when crank success.
- f. Configurable input port 1-5 cannot set for the same items, otherwise cannot appear correct function, configurable output 1-4 can be set for the same item.
- g. If need to shutdown after cooling, please set any one configurable input as "stop after cooling", then connect this input with GND.

● Information

LCD will display the controller software version, issue date.

Note: Press the key  will display the states of configurable input port and output port state.

● Set language

User may set display interface language as Chinese, English and Spanish.

* **Remark:** Press the key  will exit setting interface at any time.

9 SENSOR SETTINGS

1. When the choice sensor, the sensor to standard curve will call. If factory set temperature sensor for SGX (resistance-type), sensor curve for SGX (resistance-type), 120 degrees Celsius (elected SGD type), resistively curve for temperature sensor SGD curve.
2. If use standard sensor with the curve, can differ option "item sensor curve input", after adjusting adjustment can be determined according to save.
3. When the input sensor curve, X (resistance) must be in accordance with the order of big from small, otherwise will enter errors.
4. When the sensor is choosing "nothing", the sensor curves no affection, LCD display temperature or pressure for---
5. If there is no pressure sensor, only low pressure alarm switch, it must be alarm settings for pressure sensor "nothing", otherwise may appear oil pressure low alarm shutdown.
6. Can set up several point of forehead or several point of backmost ordinate the same. The following picture:

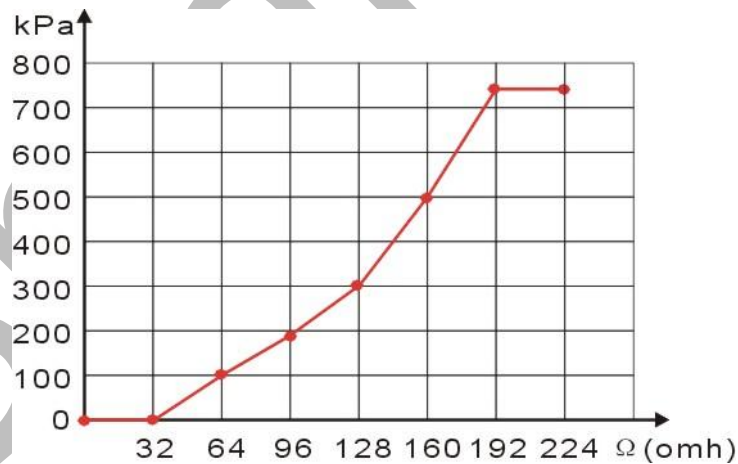

Common unit's conversion table

	1N/m ² (pa)	1kgf/cm ²	1bar	(1b/in ²) psi
1Pa	1	1.02x10 ⁻⁵	1x10 ⁻⁵	1.45x10 ⁻⁴
1kgf/cm ²	9.8x10 ⁴	1	0.98	14.2
1bar	1x10 ⁵	1.02	1	14.5
1psi	6.89x10 ³	7.03x10 ⁻²	6.89x10 ⁻²	1

10 COMMISSIONING

Before operation, inspections that are recommended as follows should be carried out:

- 1) Check and assure that all connections are correct, and that diameter of line is suitable;
- 2) The DC power supply of controller is equipped with fuse, and the positive supply (+Ve) and negative supply (-Ve) connected with battery are connected correctly;
- 3) The emergency stop input is connected with the positive supply (+Ve) of the battery through the NC terminal and fuse of emergency stop button;
- 4) The suitable operation should be taken to prevent the engine from crank success (such as dismantling the connection of fuel), check and assure that it is correct, then connect with battery, select manual mode, the controller will execute program;
- 5) Press down the starting button on the panel of controller, the engine will crank, after starts have been carried out according to setting crank numbers, the controller sends the signal that indicates crank failure; Press the Stop/Reset key to make the controller resetting;
- 6) Restore the measure that prevents the engine from crank success (such as restoring the connection of fuel), press down the starting button again, the engine will crank, if crank is normal, the genset will operate from idle operation (if idle has been set) to normal operation. In the meantime, observe the operation situation of engine and the voltage and frequency of the AC genset. If there is abnormal, stop the genset, then check connections of each part according to this handbook;
- 7) Select automatic state through front panel, then switch on the mains voltage, the controller switches over ATS (if it exist) to mains on load after pass through the mains normal delay, after cooling time, and then shut down to go into standby state until the mains is abnormal again;
- 8) After the mains is abnormal again, the Genset will automatically crank into normal operation state, and then close genset relay, control the ATS to switch transfer to genset on load. If the situation is not same as described above, check the connection of control part of the ATS according to this handbook;
- 9) If there are other questions, please contact the technical personnel of Smartgen immediately.

11 TYPICAL WIRING DIAGRAM

HGM6010KC Typical wiring diagram

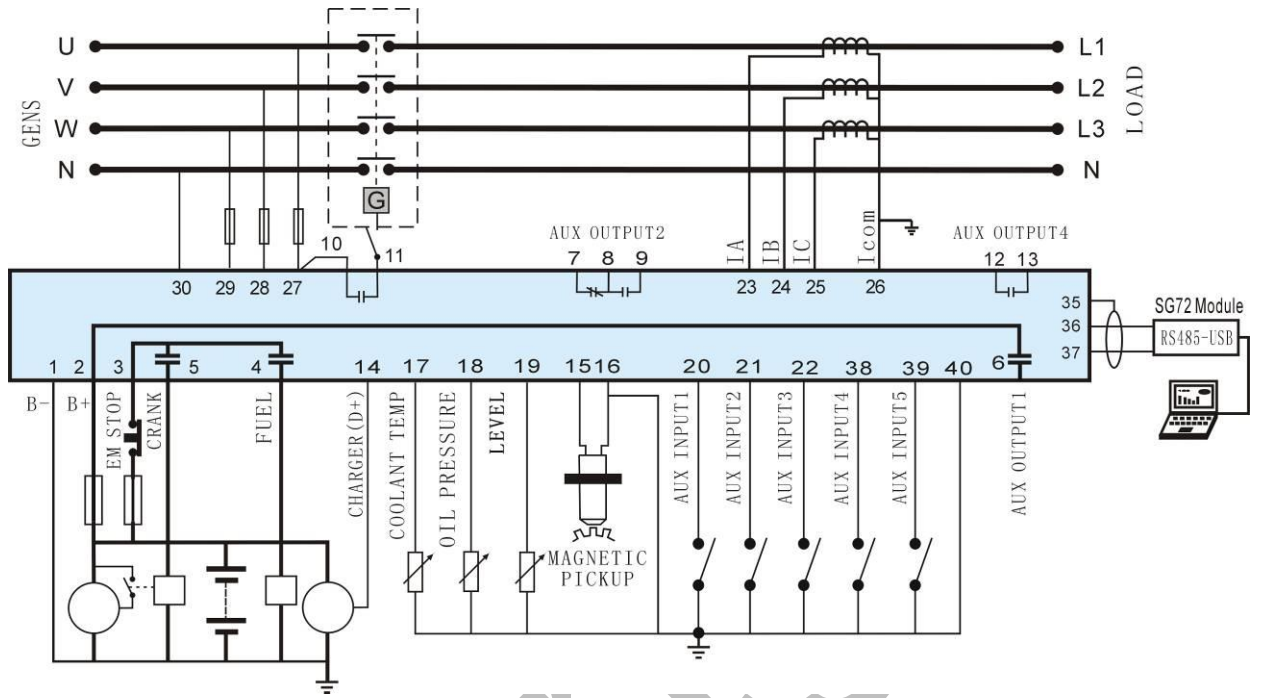

HGM6020KC Typical wiring diagram

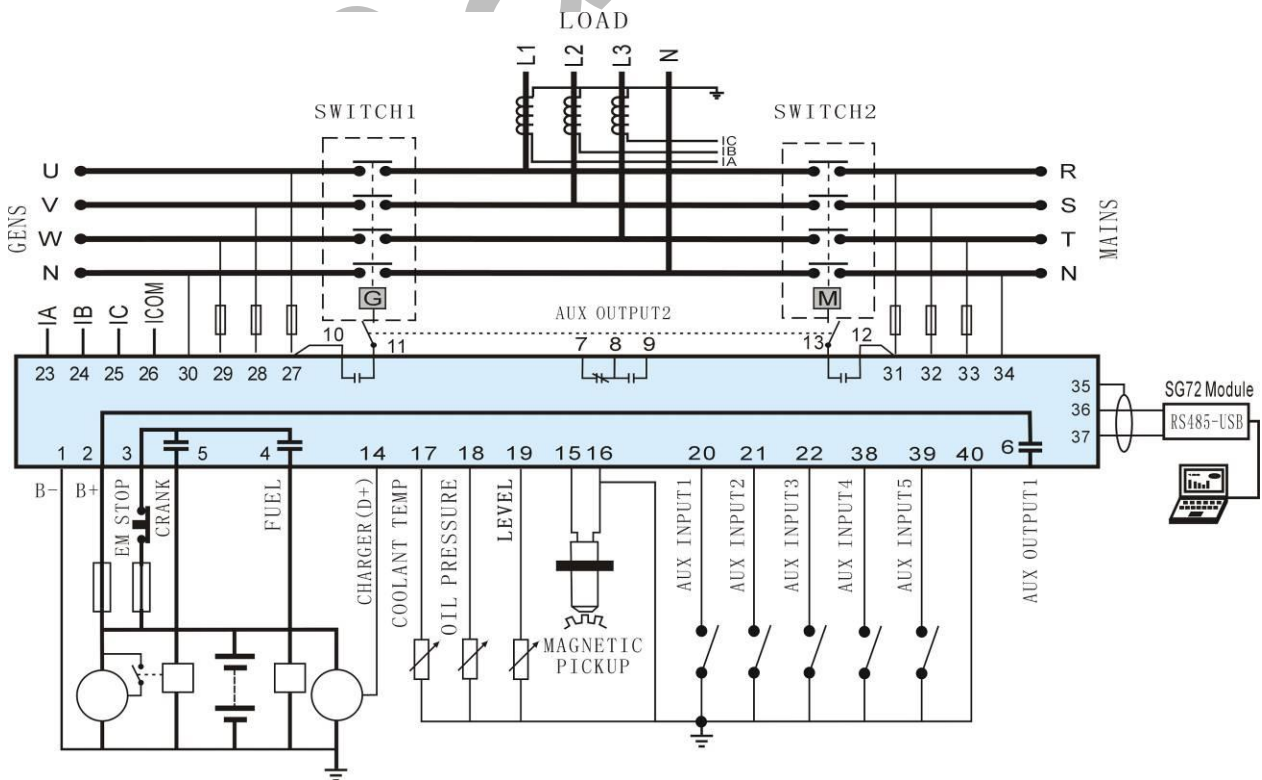

Single phase 2 wires (HGM6020KC)

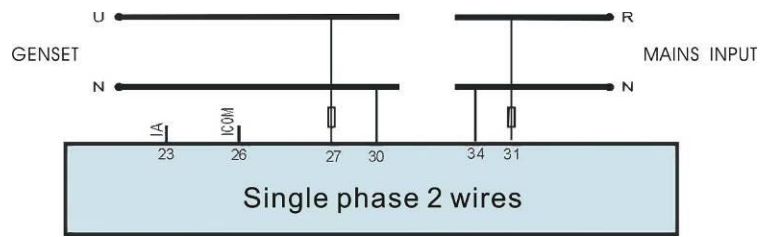

2-phase 3 wires (HGM6020KC)

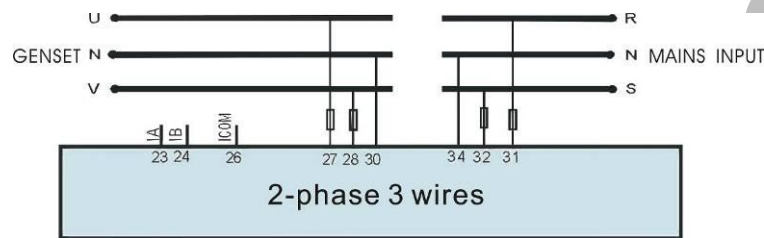

Note: Recommend that the output of crank and Fuel expand high capacity relay.

12 INSTALLATION

The controller is designed to panel installation mode, and it is fixed by clamps when it is installed. The overall dimension and panel tapping dimension are given as follows:

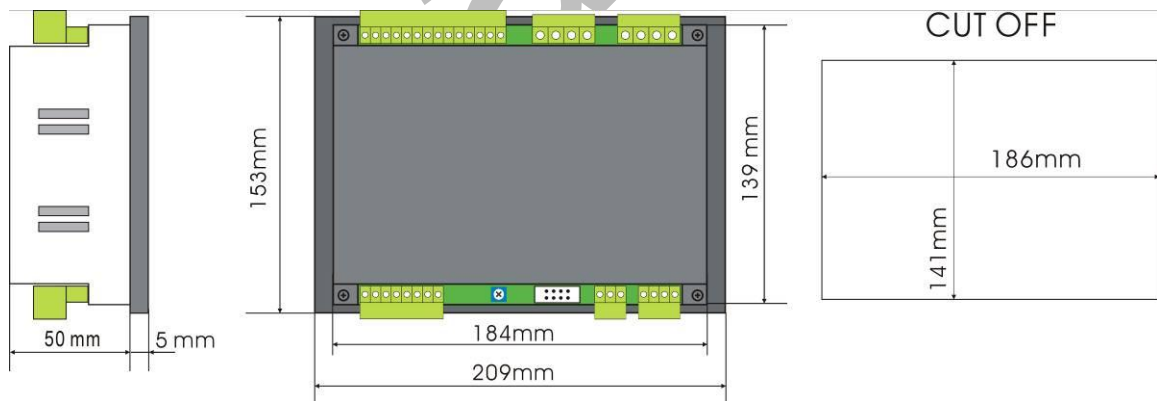

1. Battery voltage input

HGM6000K series controller can be applicable to (8-35VDC) battery voltage environment, battery anode must be reliable connect engine shell B + and B- controller power battery anode and cathode connections is not less than 2.5, if there was the float electrical, please put the charger output wire directly to battery is negative, and from the battery is connected to the anode separately on the power input, positive controller to prevent the normal operation of the controller battery charger interference.

2. Speed sensor input

Speed sensor is installed in the engine block of magnetic device testing flywheel teeth, it should be used with the controller of attachment 2 core shielding line, shielding layer on the 16th pin controller, the other end terminal, the other two are respectively in signal controller, and meet the terminals 15th and 16th pin. At full speed sensor output voltage range should be in 1-24VAC (RMS), recommend voltage for 12VAC (in the rated speed). When the velocity sensor can be installed to contact the flywheel spinning sensor first, then pour out 1/3 laps, finally will lock nut on the sensor.

3. Output and relays

Controller for all output relay contacts output, if need to expand relays, please will expand relay coil free-wheeling diode (increased ends when extended relay coil links DC) or increase resistance and capacitance loop (when extended relay coil links AC), in order to prevent interference controller or other equipment.

4. Alternating current input

HGM6000K series controller to external input current transformer, electric current transformer side must be 5A, while the current transformers for phases and the phase of the input voltage must be correct, otherwise the current and sampling the active power may be incorrect.

Note: A. ICOM must connect battery anode power controllers.

B. When the load current, the transformer secondary side is strictly open circuit.

5. Pressure test

When the controller has been installed in the control panel, if you will, please put pressure test controller terminals all disconnected, lest high-pressured into and damaged controller.

13 FAULT FINDING

Symptom	Possible Remedy
Genset inoperative	Check the battery and wiring to the unit. Check the DC supply. Check the DC fuse.
Genset shutdown	Check water/cylinder temperature whether or not too high. Check AC genset voltage. Check the DC fuse.
Emergency shutdown	If an Emergency Shutdown switch is not fitted,

Symptom	Possible Remedy
	<p>ensure that a positive is connected to the Emergency shutdown input.</p> <p>Check emergency shutdown switch is functioning correctly.</p> <p>Check wiring is not open circuit.</p>
Low oil Pressure alarm (after crank success)	<p>Check engine oil pressure.</p> <p>Check oil pressure switch/sensor and wiring.</p> <p>Check configured polarity (if applicable) is correct.</p>
High Temp. alarm (after crank success)	<p>Check engine temperature.</p> <p>Check switch/sensor and wiring.</p> <p>Check configured polarity is correct.</p>
Shutdown fault operates	<p>Check relevant switch and wiring of fault indicated on LCD display.</p> <p>Check configuration of input.</p>
Crank no success	<p>Check wiring of fuel solenoid.</p> <p>Check battery supply.</p> <p>Check wiring of the speed sensing signal.</p> <p>Refer to engine manual.</p>
Crank failure	<p>Check wiring of fuel solenoid.</p> <p>Check fuel.</p> <p>Check battery supply.</p> <p>Check battery supply is present on the Fuel output of the module.</p> <p>Check the speed sensing signal is present on the 6000K series inputs. Refer to engine manual.</p>
Unit operation but ATS	<p>Check ATS.</p> <p>Check the connection between the ATS and the controller.</p>
RS485 communication abnormal	<p>Check wiring.</p> <p>Check COM ports set correctly.</p> <p>Check the A and B RS485 line is reversed.</p> <p>Check of RS485 conversion module.</p> <p>Check the PC communications port is damaged.</p> <p>Suggest that the A and B lines of the 485 network should be terminated at each end with a 120Ω resistor.</p>