

# Smartgen®

HAT72

Automatic Transfer Switch Control Module

## OPERATING MANUAL

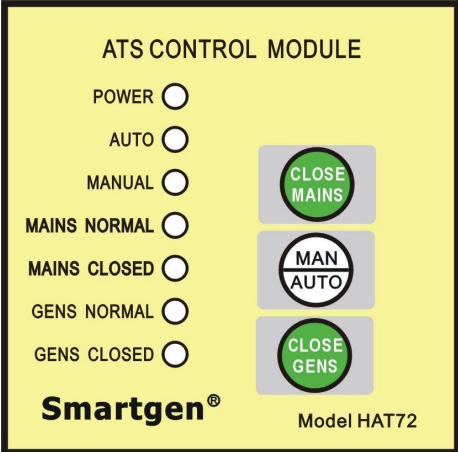

Smartgen Electronics

## Software Version

Version	Date	Note
2010-03-19	1.1	Original release.

# Smartgen®

**Smartgen Electronic Equipment Co., Ltd**

**No.28 Jinsuo Road**

**Zhengzhou**

**Henan Province**

**P.R.China**

**Tel : (0086)-371-67992951 67991572**

**Fax: (0086)-371-67992952**

Web: <http://www.smartgen.com.cn>  
<http://www.smartgen.cn>

Email: [sales@smartgen.com.cn](mailto:sales@smartgen.com.cn)

All rights reserved. No part of this publication may be reproduced in any material form (including photocopying or storing in any medium by electronic means or other) without the written permission of the copyright holder.

Applications for the copyright holder's written permission to reproduce any part of this publication should be addressed to Smartgen Electronics at the address above.

Any reference to trademarked product names used within this publication is owned by their respective companies.

Smartgen Electronics reserves the right to change the contents of this document without prior notice.

HAT72 is an **Automatic Transfer Switch Control Module**. The module features 8-Bit microprocessor control. The module is used to monitor two single-phase AC supply. Once mains AC supply failure are detected (under voltage, over voltage, under frequency, over frequency), The module will control generator to start. If generator AC can load, The module automatically transfer the switch to generator AC supply,

## ●FEATURES

- ★ Micro-processor based design;
- ★ Meter two single-phase AC Voltages;
- ★ Set AUTO or MANUAL via PUSHBOTTON mounted on the front panel;
- ★ Two isolable N designed;
- ★ 7 LEDs display the status;
- ★ Operational timers can be altered by PC;
- ★ Control generator to Start;

## ●SPECIFICATION

- ◇ **DC supply:** 8 to 35V(1.5VA)
- ◇ **single-phase AC input:** AC30~277V (+20%) 50/60Hz
- ◇ **Relay output:**
  - Relay of close mains & close gens: 16A 250VAC
  - Relay of start generator: 5A 250VAC
- ◇ **Delay timers:**
  - Mains Normal delay time: 0~3600s
  - Mains Abnormal delay time: 0~3600s
  - Gens Normal delay time: 0~3600s
  - Start generator time:0~3600s(after Mains is abnormal)
  - Stop generator time:0~3600s(after Mains is normal)
  - Close time:0~20.0s
  - Over close time: 0~5.0s
  - Between close time: 0~3600s
- ◇ **Critical value**
  - Mains under voltage:0~360V
  - Mains over voltage:0~360V
  - Gens under voltage:0~360V
  - Gens over voltage:0~360V
  - Gens under frequency: 0~60.0Hz
  - Gens over frequency:51.0~75.0Hz
- ◇ **Accessorial input**
  - state can be altered by PC
- ◇ **Operating Temperature Range:**

-30 to +70°C

## ● DISPLAY SYMBOL and OPERATION

### ◎ PUSH BUTTON

Symbol	Define	Description
Close Mains	Mains close button	At MAN state, push this button, ATS will turn to the mains
MAN/AUTO	MAN/AUTO state switch button	Switch the state to MAN or AUTO
Close Gens	Generator close button	At MAN state, push this button, ATS will turn to the Generator

### ◎ LED

Symbol	Define	Description
Power	Power led	Lighten when DC supply
Auto	Auto state led	Lighten when Module at auto state
Manual	Man state led	Lighten when Module at man state
Mains Normal	Mains normal led	Lighten when mains is normal; Flicker when mains is abnormal; Die when mains is lost.
Mains Closed	Mains closed led	Lighten when mains load
Gens Normal	Generator normal led	Lighten when Generator is normal; Flicker when Generator is abnormal; Die when mains is lost.
Gens Closed	Generator closed led	Lighten when Generator load

### ◎ OPERATION

Module has two states: MAN state and AUTO state: the state can be switch by MAN/AUTO button, the state can be display by Auto state led and Man state led.

#### ★MAN state

When Man state led is lighten, the module is at man state. Here, push (CLOSE Mains) button, the relay of close mains will output, push (CLOSE Gens) button, the relay of close Generator will output.

At this state, the relay of start generator is unable.

★**AUTO state**

- ◆ When Auto state led is lighten, the module is at auto state. Here. When mains is normal, ATS will turn to the mains after the Mains Normal delay time. When mains is abnormal(under voltage, over voltage, lost voltage), after the Mains Abnormal delay time and Start generator time the relay of start generator will output and the generator will start. If the Generator is normal, ATS will turn to the Generator after the Gens Normal delay time.
- ◆ When mains is normal, ATS will turn to the mains after the Mains Normal delay time.
- ◆ When mains is normal, the relay of start generator will be unable and the generator will stop after the Stop generator time.

© parameters table (only adjust via PC)

Parameter	Description	Range(Default)
Mains normal delay	It is the delay of Mains power from abnormal to normal.	0-3600S (10)
Gens normal delay	It is the delay of Mains power from abnormal to normal.	0-3600S (10)
Mains abnormal delay	It is the delay of Mains power from normal to abnormal.	0-3600S (5)
Start GENS Delay	It is the delay from Mains power is abnormal to send out start generator signal.	0-3600S (1)
Stop GENS Delay	It is the delay from Mains power is normal to send out stop generator signal.	0-3600S (5)
ATS close time	Breaker close pulse. If it is set to zero, the output will held.	0-20.0S(5.0)
Transfer rest time		0-3600S (1)
Exceed Convert Time	After the module has received a close state input, the breaker close output continue to held until the delay is expended.	0-5.0S(0)
Mains over voltage	The setting are used to configure the Mains power over voltage point	0-360V (276)
Mains under voltage	The setting are used to configure the Mains power under voltage point	0-360V (184)
Gens over voltage	The setting are used to configure the Gens power over voltage point	0-360V (264)

Gens under voltage	The setting are used to configure the Gens power under voltage point	0-360V (192)
Gens over frequency	When the frequency of Gens power is over than the point, over frequency is active.	51-75Hz(55.0)
Gens under frequency	When the frequency of Gens power is low than the point, low frequency is active.	0-60Hz(45)
Yes or No close input is connect		(Yes)

## ● TERMINAL

- ◆ Terminal 1 (B-): connect to the cathode of battery
- ◆ Terminal 2 (B+): connect to the anode of battery
- ◆ Terminal 3(Close Generator Input): Generator supply closed auxiliary input, connect to (B-) is active
- ◆ Terminal 4、 5 (Generator Start Output): output of Relay of start generator (volts free ,5A250V)
- ◆ Terminal 6、 7 (Generator AC Input): Generator AC Input
- ◆ Terminal 8、 9 (Mains AC Input): Mains AC Input
- ◆ Terminal 10、 11 (Close Mains Output): output of Relay of close mains (volts free ,16A250V)
- ◆ Terminal 12、 13 (Close Generator Output): output of Relay of close generator (volts free ,16A250V)
- ◆ Terminal 14(Close Mains Input): Mains supply closed auxiliary input, connect to (B-) is active
- ◆ Terminal (LINK): connect to PC by SG72

● CASE DIMENSIONS(hole:67\*67mm)

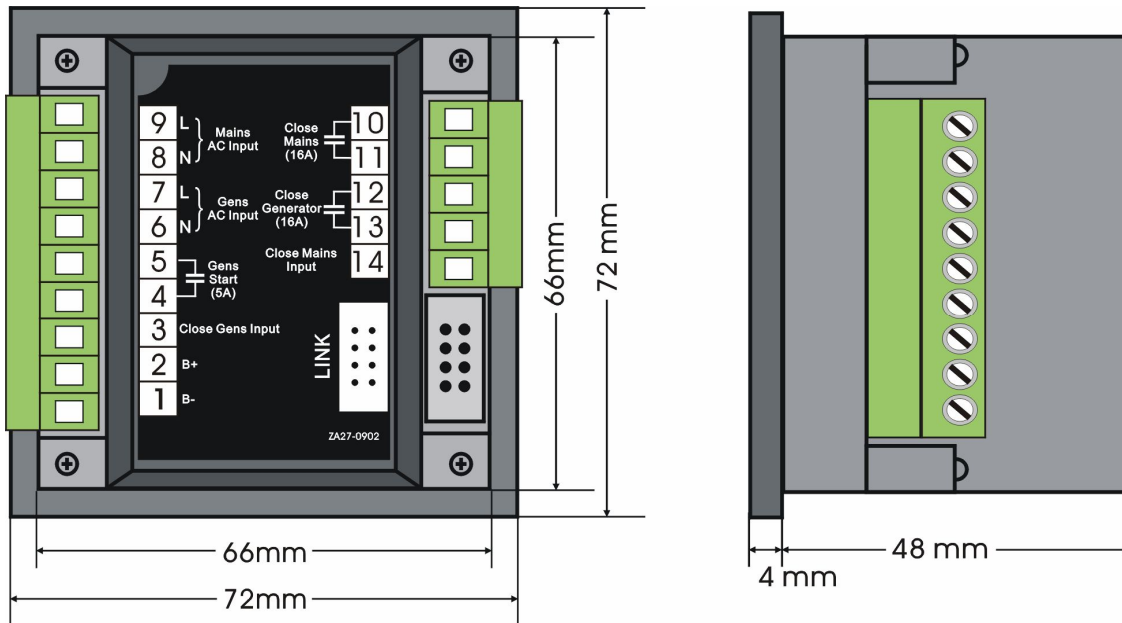

● TYPICAL CONNECTIONS

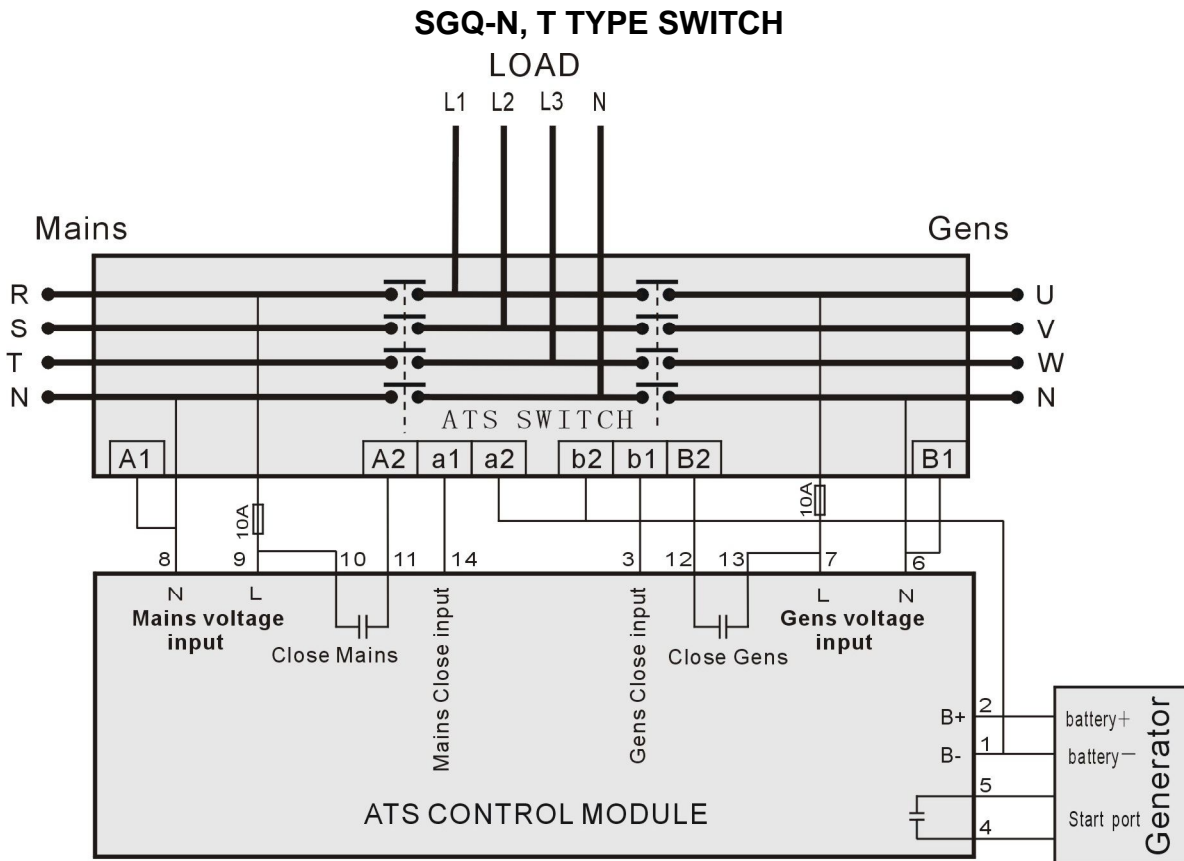

**SGQ-M TYPE SWITCH**

