

Smartgen®

HAT220A/HAT240A

ATS (Automatic Transfer Switch) CONTROLLER

OPERATING MANUAL



Smartgen Electronic

Smartgen®

Smartgen Electronic Equipment Co., Ltd

No.28 JinSuo Road

ZhengZhou

HeNan Province

P. R. China

Tel: 0086-371-67988888/67981888
0086-371-67991553/67992951/67992952
0086-371-67981000(overseas)

Fax: (0086)-371-67992952/67981000

Web: <http://www.smartgen.com.cn>
<http://www.smartgen.cn>

Email: sales@smartgen.com.cn

All rights reserved. No part of this publication may be reproduced in any material form (including photocopying or storing in any medium by electronic means or other) without the written permission of the copyright holder.

Applications for the copyright holder's written permission to reproduce any part of this publication should be addressed to Smartgen Electronics at the address above.

Any reference to trademarked product names used within this publication is owned by their respective companies.

Smartgen Electronics reserves the right to change the contents of this document without prior notice.

Software Version

Version	Date	Note
1.0	2010-05-20	Original release.
1.1	2011-05-20	Modify programmed operation step of the controller panel.

CONTENT

1	SUMMARY	4
2	PERFORMANCE AND CHARACTERISTICS	4
3	TECHNICAL SPECIFICATIONS	5
4	PANEL OPERATION INSTRUCTION	6
5	PANEL OPERATION AND DIAGRAM CONNECTION	6
5.1	DELAY ADJUSTMENT	6
5.2	RECOVER DEFAULT DELAYS VALUE	7
6	PROGRAMMED PARAMETER AND RANGE	7
7	OPERATION CONTROL	8
8	FUNCTION OF TERMINALS	9
9	TYPICAL WIRING DIAGRAM	10
10	OVERALL AND MOUNTING DIMENSIONS	11
11	FAULT FINDING	11

1 SUMMARY

HAT220A/HAT240A ATS controller has microprocessor as its core, can accurately detect 2 ways-3 phase, 2 ways-1 phase or 2ways-2phase voltage and also can make accurate judgment to conditions of abnormal voltage (loss of electricity, over or under voltage), control ATS to transfer after delay. Controller also has a function of sending start signal to genset when one power is abnormal.

2 PERFORMANCE AND CHARACTERISTICS

Controller detect multi-voltage conditions, such as 2ways-3phase voltage, 1phase voltage (could be 2 ways mains, 2ways gens, or 1mains-1gens), or 2ways-2phase voltage. Its performance and characteristics show as following,

- Realizing the computer programming control, can use computer to set abnormal voltage delay, switch priority, genset shutdown delay, the voltage correction and other functions, fully graphical interface operation. When programming by computer, the controller front panel must be opened, then use SG72 interface module (USB to LINK) via the PC test software. About PC software's operation, please refer to "software manual of HAT220A/HAT240A".
- The voltage normal delay of #I or #II can be set (0~60) seconds and the start Genset delay can be set (0~90) seconds.
- The voltage abnormal delay of #I or #II can be set (0~60) seconds and the stop Genset delay can be set (0~90) seconds.
- "#I power supply priority", "Auto/Manual", "No priority" and "#II power supply priority" can be set via controller front panel and in order to ensure #I power supply priority power on or #II , or no priority power on for examine and repair.
- Design of 2 ways N line isolate.
- LEDs mounted on front panel can clearly show ATS running status.
- The #I and #II power supply transfer relay's (CLOSE 1#, CLOSE 2#) output contactor capacity is 16A 250VAC/16A 28VDC, and they belong to passive contactor, can be directly used in driving switch to transfer.
- The Genset start relay's (GENS START) output contactor capacity is 7A 250VAC/7A 28VDC, and they belong to passive normally closed contacts.
- Controller has strong ability for anti-electromagnetic interference, and very suitable for using in strong electromagnetic interference of complex environment.
- Modular configuration design, Flame Retardant ABS plastic shell, inserted type

connection terminals, small volume, compact structure with easy mounting and maintenance.

3 TECHNICAL SPECIFICATIONS

a) Rated voltage and frequency input:

3-phase AC 380V 50/60Hz 3-phase 4 -wire (used for 220A controller)
1-phase AC 230V 50/60Hz Single-phase 2-wire (used for 240A controller)
Over voltage threshold, 264 V (phase-N)
Under voltage threshold, 172 V (phase-N)
AC voltage measurement accuracy, 2%
AC phase-N voltage measurement range, (160~300) V \pm 20%

b) Action time

- ◆ Break on feedback time: 5 seconds. During break on procedure, if switch break on status signal is detected, break off immediately.
- ◆ Power supply normal delay: (0~60) seconds (can be adjusted via controller front panel potentiometer).
- ◆ Power supply abnormal delay: (0~60) seconds (can be adjusted via controller front panel potentiometer), default setting, 5 seconds
- ◆ Genset start delay: after 1# abnormal delay (0~60) seconds (can be adjusted via controller front panel potentiometer), genset start relay energize.
- ◆ Genset stop delay: after 1# normal delay (0~90) seconds (can be adjusted via controller front panel potentiometer or PC, default setting: 90 seconds), genset start relay un-energize.

c) Power consumption

Less than 2VA at rated voltage.

d) Environment conditions

Working temperature: (-30~+70) °C; Humidity: (20~95) %

e) Weight

Net weight: 0.47Kg

4 FRONT PANEL OPERATION INSTRUCTION

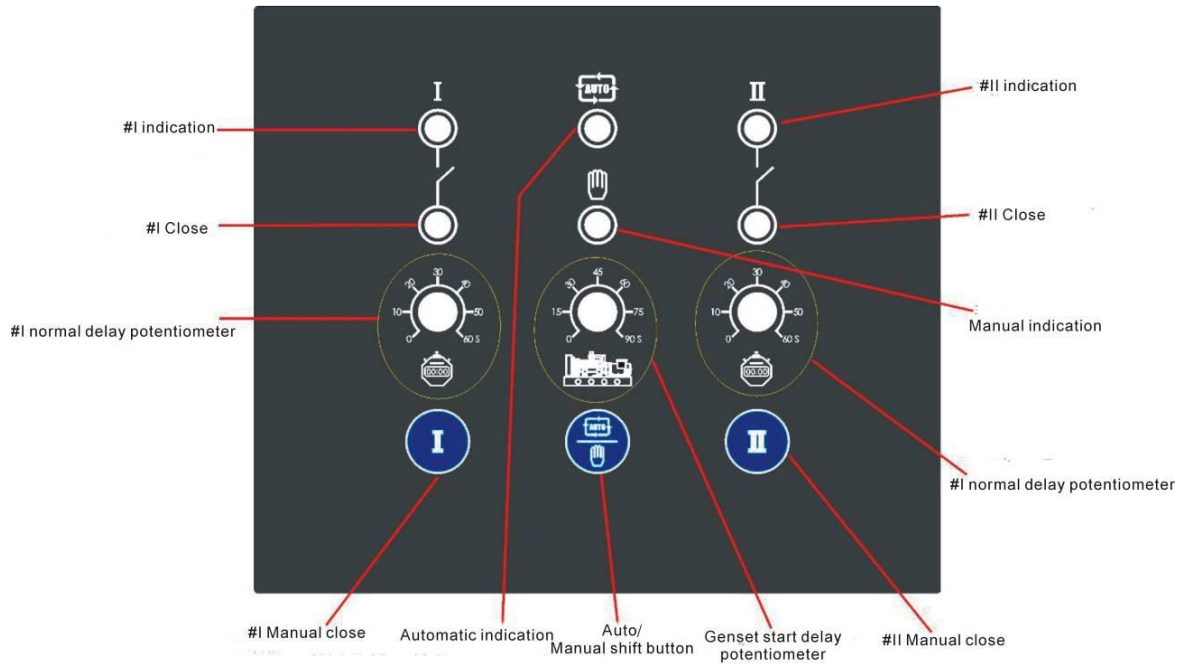

5 FRONT PANEL OPERATION

5.1 DELAY ADJUSTMENT

- ◆ Adjusting potentiometer of “#I power supply normal delay” can set output delay after #I power supply normal.
- ◆ Adjusting potentiometer of “#II power supply normal delay” can set output delay after #II power supply normal.
- ◆ Adjusting potentiometer of “Genset start delay” can set genset start signal output delay after #I power supply abnormal.

Procedures of setting “#I power supply abnormal delay”, “#II power supply abnormal delay” and “Genset stop delay” show as following:

- a) Press **I** key and **II** key simultaneously, when #I power supply indication lamp, automatic status indication lamp and #II power supply indication lamp simultaneously illuminate, loose **I** key and **II** key, #I power supply indication lamp, automatic status indication lamp and #II power supply indication lamp will not illuminate simultaneously, then controller enters into delay setting status:

- 1) Set “#I power supply abnormal delay” by adjusting potentiometer of “#I power

supply normal delay”;

2) Set “#II power supply abnormal delay” by adjusting potentiometer of “#II power supply normal delay”;

3) Set “Genset stop delay” by adjusting potentiometer of “Genset start delay”.

b) After adjustment, press **II** key, when #I power supply indication lamp, automatic status indication lamp and #II power supply indication lamp are illuminate simultaneously, show that every adjust values of potentiometer are saved successfully. The controller will work depending upon setting delay values.

5.2 RESTORE DEFAULT DELAYS VALUE

a) Press **I** key and **II** key simultaneously, when #I power supply indication lamp, automatic status indication lamp and #II power supply indication lamp illuminate simultaneously, loose **I** key and **II** key, #I power supply indication lamp, automatic status indication lamp and #II power supply indication lamp will not illuminate simultaneous, controller enters into delay value setting status;

b) Press **III** key, when #I power supply indication lamp, automatic status indication lamp and #II power supply indication lamp illuminate simultaneously, will restore factory setting value. The controller will work depending upon default delay values.

Note: Factory setting value is 5 seconds of #I, #II abnormal delay, and 90 seconds of genset stop delay.

6 PROGRAMMED PARAMETER AND RANGE



Num	Name	Range	Default	Remark
1	#I voltage normal delay	(0~60)s	Can be set via controller panel potentiometer	It can only be set via controller panel potentiometer
2	#II voltage normal delay	(0~60)s		
3	Genset start delay	(0~60)s		
4	Genset stop delay	(0~90)s	90s	It can be set via controller panel potentiometer or PC setting
5	#I voltage Abnormal delay	(0~60)s	5s	
6	#II voltage abnormal delay	(0~60)s	5s	

7	Voltage upper limit value	(50~300)V	264V	It can only be set via PC
8	Voltage lower limit value	(50~300)V	172V	
9	Transfer priority	1# priority, 2# priority, no priority	1# priority	It can be set via controller panel potentiometer or PC
10	AC option	3 phase 4 wire Single-phase 2 wire	3 phase 4 wire	It can only be set via PC







Note: In the above table of ten items, select “3-phase 4-wire” is used to HAT220A; select “single-phase 2-wire” when used HAT240A controller.

7 OPERATION CONTROL

Auto/Manual operation,

When controller in running, press  key to transfer controller into Auto or Manual mode (Mode is indicated by lamps of Auto and Manual). In Manual mode, press  key, load transfer into #I power supply side and press  key, load transfer into #II power supply side.

Procedures of setting “#I power supply priority”, “#II power supply priority” and “No priority” show as following:

- a) Press  key,  key and  key simultaneously, when #I power supply indication lamp, automatic status indication lamp and #II power supply indication lamp illuminate simultaneously, loose  key,  key and  key, then automatic status indications lamp and #II power supply indication lamp will not illuminate, #I power supply indication lamp illuminate, then controller enters into setting priority status.
- b) Press  key can circularly set three priority status:
 - 1) When #I power supply indication lamp illuminate, at the same time #II power supply indication lamp isn't illuminate, for #I transfer priority;
 - 2) When #II power supply indication lamp illuminate, at the same time #I power supply indication lamp isn't illuminate, for #II transfer priority;
 - 3) When #I power supply indication and #II power supply indication lamp illuminate

simultaneously, then for no transfer priority.

- c) After adjustment, press **II** key, when #I power supply indication lamp, automatic status indication lamp and #II power supply indication lamp illuminate simultaneously, the setting priority value will be saved successfully, then controller will work depending upon setting priority status.

Note: each time controller power supply is opened; priority level can be indicated by following three conditions.

- 1) If #I power supply indication lamp is flashing rapidly 3 times, for #I power supply priority;
- 2) If #II power supply indication lamp is flashing rapidly 3 times, for #II power supply priority;
- 3) If #I and #II power supply indication lamps are flashing rapidly 3 times simultaneously, it is no priority.

8 FUNCTION OF TERMINALS



- ◆ Terminal A1, B1, C1, N1 is separately connected to A, B, C, N of #I power supply. (For HAT240A, A1, N1 is separately connected to A and N of #I power supply).
- ◆ Terminal A2, B2, C2, N2 is separately connected to A, B, C, and N of #II power supply. (For HAT240A, A2, N2 is separately connected to A and N of #II power supply).
- ◆ Terminal L1: #I Breaker on feedback input (active when connect AC220V).
- ◆ Terminal L2: #II Breaker on feedback input (active when connect AC220V).
- ◆ Terminal M1, M2: Passive contactor of closing #I relay (contactor capacity is 16A 250VAC/16A 28VDC).
- ◆ Terminal M3, M4: Passive contactor of closing #II relay (contactor capacity is 16A 250VAC/16A 28VDC).
- ◆ Terminal M5, M6: Passive normally closed contactor of genset start relay (contactor capacity is 7A 250VAC/7A 28VDC).

9 TYPICAL WIRING DIAGRAM

HAT220A

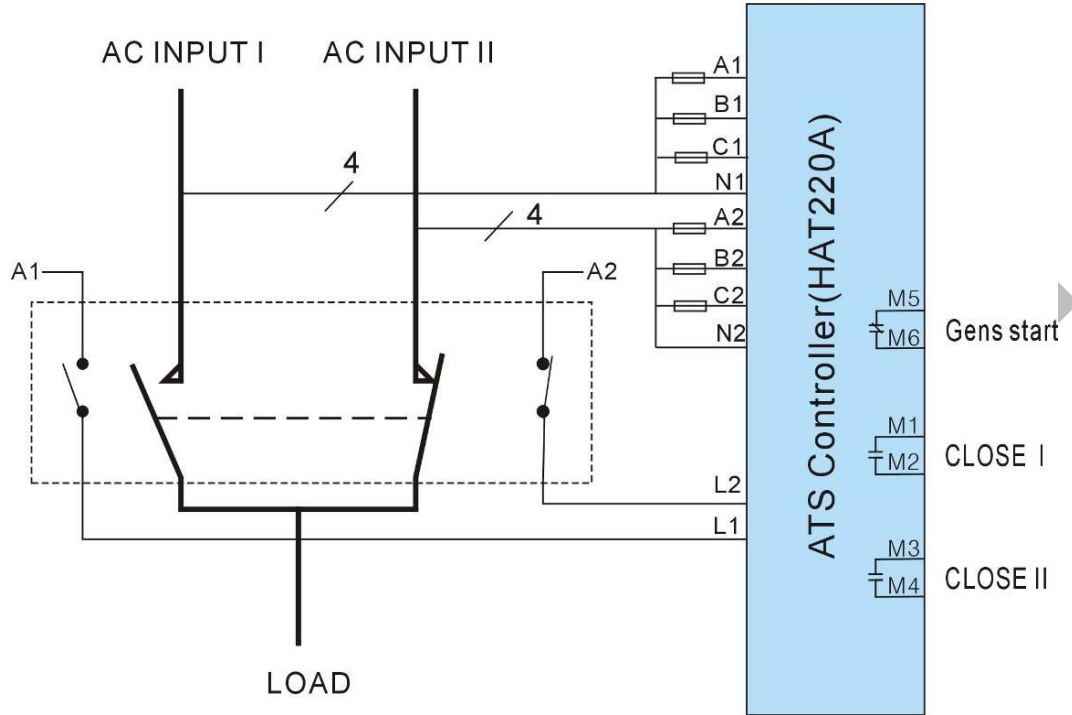

HAT240A

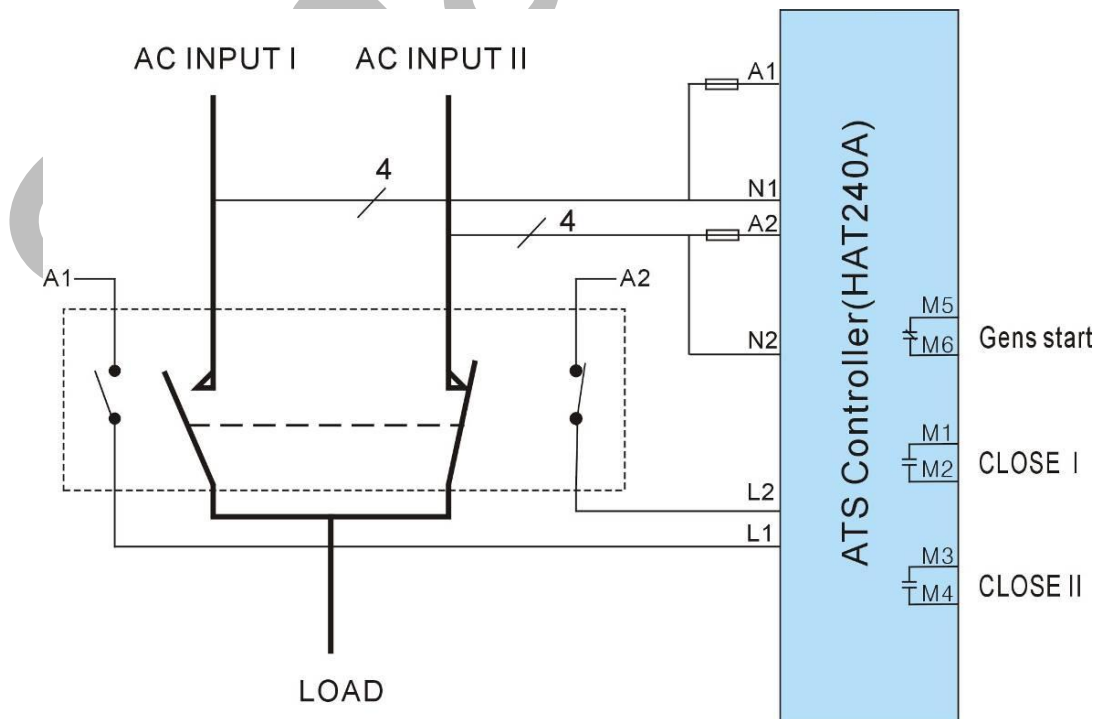

10 CASE AND DIMENSIONS

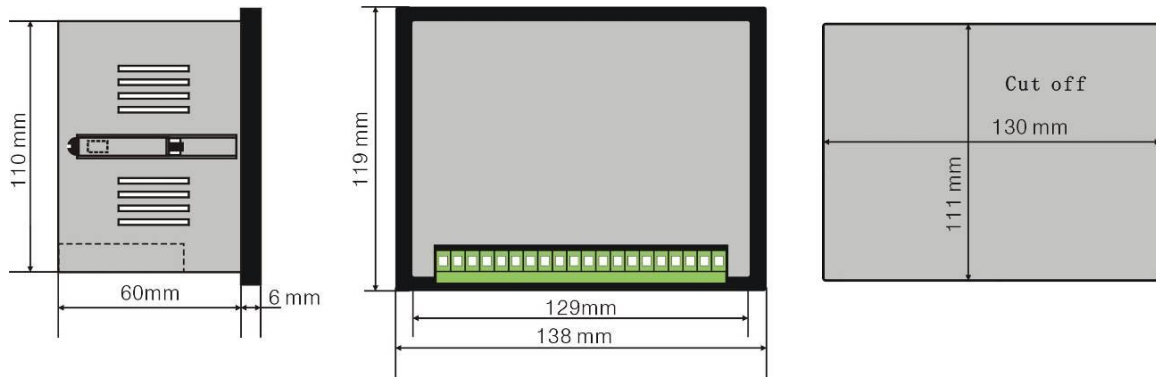

11 FAULT FINDING

Fault Symptom	Possible Remedy
Controller no operation	Check connection wirings of controller
ATS is not working	Check ATS Check the connection wirings between the controller and the ATS
Electric parameters detecting error	Check connection wirings of controller and amend detecting values of electric parameters.
Communication error with PC	Check setting of communication port and its wirings.